

# Commissioning instruction for electrical braking units (standard) HBR 20-400 to HBR 200-400

## Technical data

Braking unit type:	HBR 20	HBR 40...60	HBR 100	HBR 200
Maximum braking current:	20A	40A...60A	100A	200A
Maximum braking times:	30s	30s	30s	30s
Nominal voltage range:	① 380 V - 400 V, ② 208 V - 230 V			
Frequency:	50 / 60 Hz			
electronic control voltage on terminal 3-4 (option)	value according to type label			
Power input for electronics:	1,6 VA			
Terminal 1-2, terminal 8-9	0,5-4qmm,max 250VAC / 20A			
Operating temperature:	- 15°C — + 40°C			
Relative humidity:	0 % - 90 %, non-condensing			
Protection:	casing IP40, terminal IP 20 guaranty only for switchgear-cabinet installation			

The installation of the braking units must be done so that the heat sink fins are positioned vertically. Connect the braking unit according to the diagram overleaf. It is particularly important to adhere to the braking interlock conditions to guarantee a safe function of the brake. The brake has to be installed into a switchgear cabinet. To guarantee protection IP2X/IP4X the unit has to be build in into an appropriate casing.

The interlock contact (terminals 8 and 9) should be seated into the control circuit of the motor contactor in order to prevent the motor contactor from gripping during braking. Units from brake type HBR40-400 upwards need a braking contactor which is inter-locked with the motor contactor. The braking contactor should be chosen according to the DC-brake current. It switches under normal conditions always in current-free condition, because first the braking contactor and after that with a delay the braking current is switched. At the end of the braking process first the braking current and then with a delay the braking contactor is switched. The cable connection at terminal 5 and 6 has to adjusted to the mains voltage and must be twisted and shielded.

## Safety instruction

1. The protective conductor has to be always connected to the unit. In addition a heatsink has to be connected to the brakes HBR40 and upwards.
2. The pre-fuses (F2) have to chosen so high that they are suitable for the maximum braking current for which the brake is designed.
3. All connected devices have to be lay out for the nominal voltage of the mains. This also applies for the control connections.

HBR / 400V	20	40	60	100	150	200	250	300	400	500	600
braking current (rms)	20 A	40 A	60 A	100 A	150 A	200 A	250 A	300 A	400 A	500 A	600 A
pre-fuses (F2) time of activity 10%	10 A	25 A	32 A	50 A	63 A	100 A	125 A	125 A	160 A	200 A	250 A

## Commissioning

1. Switch the installation voltage-free
2. Switch a DC measuring device into the lead from the braking unit to the motor. It is essential to use a moving iron measuring instrument or another effective value measuring instrument which is independ of the type of current (no current measuring tongs, no moving coil measuring instruments), because the braking current is an undulatory voltage of direct and alternating current.
3. Setting the potentiometers
  - braking current (coarse adjustment)                      left stop position (minimum)
  - braking current (fine adjustment)                            10% of setting range
  - braking time    50% of setting range
4. Switch on installation
5. Start motor

6. Switch off motor and start braking process
7. Adjust braking current and time.

### **Setting the braking current**

ATTENTION! With the trimmers "braking current coarse adjustment/fine adjustment" the braking current can be set which means that with the same trimmer adjustment for different motors depending on its winding impedance the braking voltage may vary and maybe even exceed the nominal current of the brake which involves a destruction of the unit. Therefore the commissioning has only to be proceed as described above. The braking current has to be adjusted so that the required braking current flows. We recommend to set the braking current twice the nominal current of the motor. The maximum permissible braking current is noted on the type plate of the braking unit. To avoid an unnecessary warming up of the motor, set the braking current as small as possible.

### **Setting the braking time**

The required braking period is set with the potentiometer "braking time". The period should be set so that the braking current is switched off immediately after motor standstill.

### **LED-Displays**

Green - unit is ready to operate  
Red - unit is in braking process

### **Remarks**

In order to guarantee a safe reduction of the motor remanence voltage a delay-action time of 500 ms between the drop-out of the motor contactor and starting the braking process is built in. For motors with a capacity of more than 20kW a delay-action time of up to 2.5 s is built in. Because of thermal strain only 12 braking processes per hour are permitted. Therefore a time span of at least 5 minutes must be observed between each braking process.

# Connection Diagram

HBR 2-400 ... HBR 20-400

HBR 40-400 ... HBR 800-400

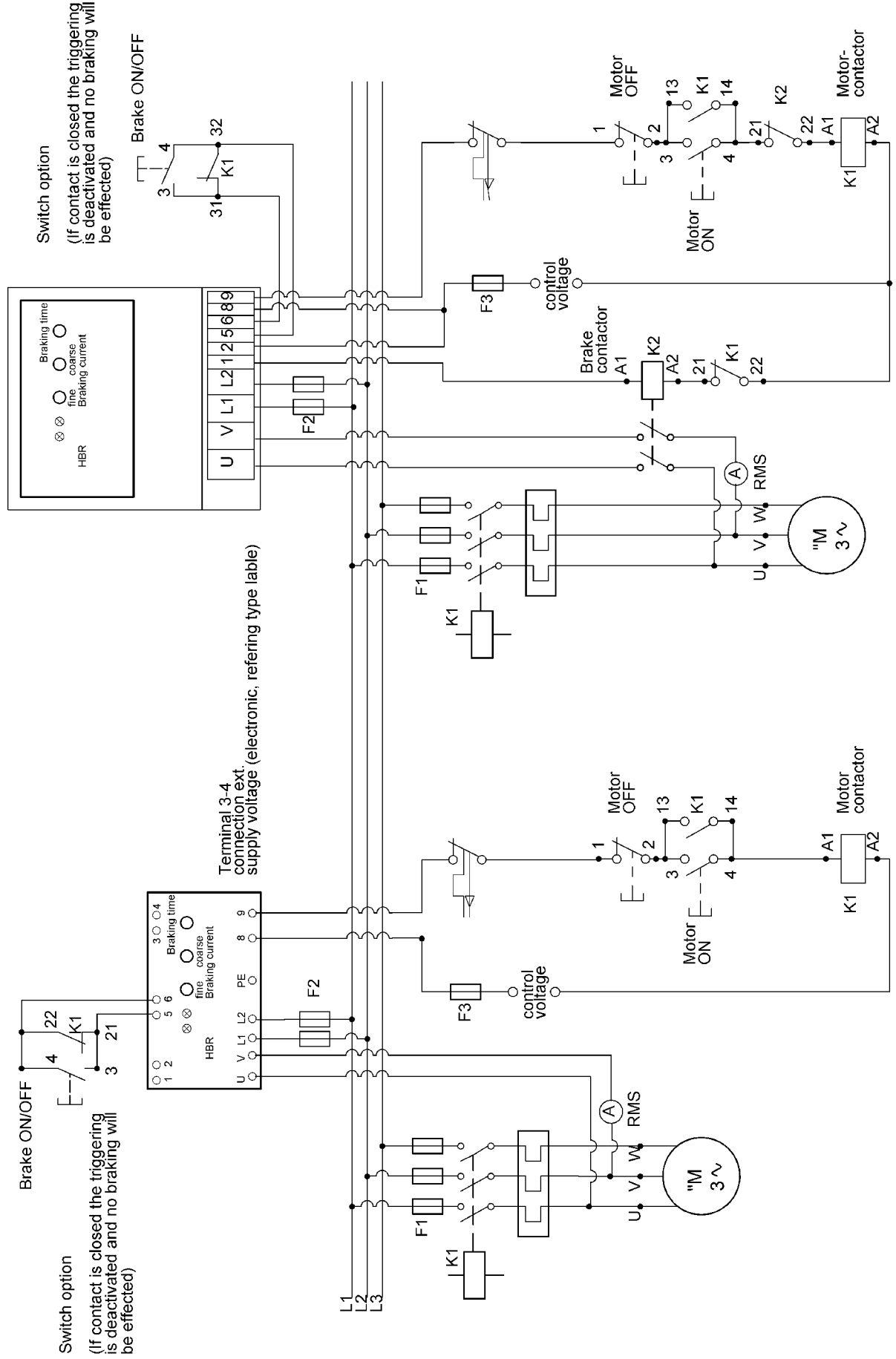

Switch option  
(If contact is closed the triggering is deactivated and no braking will be effected)

Brake ON/OFF  
(If contact is closed the triggering is deactivated and no braking will be effected)

Terminal 3-4 connection ext. supply voltage (electronic, referring type table)

F3 has to be selected to comply with the cable cross-section of the control circuit.  
F2 has to be selected in accordance with table of pre fuses F2